

RECYCLE BIN – ASSEMBLY INSTRUCTION MANUAL

Model: Mobile Recycle Bin

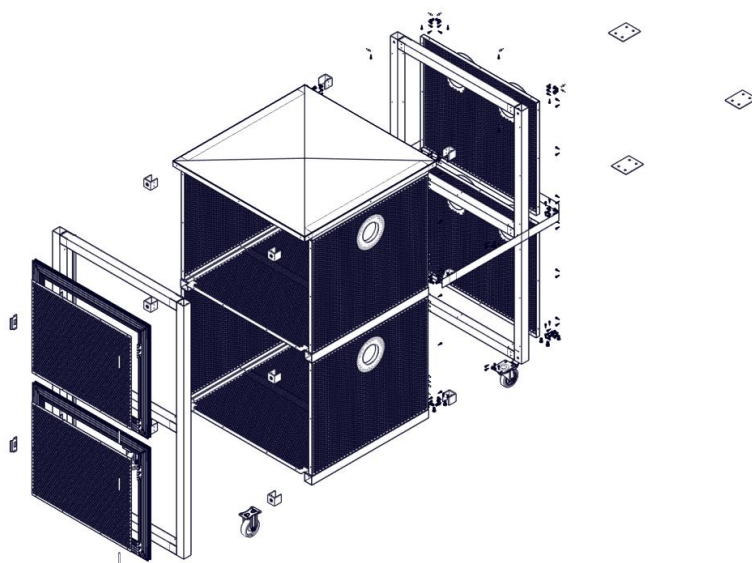

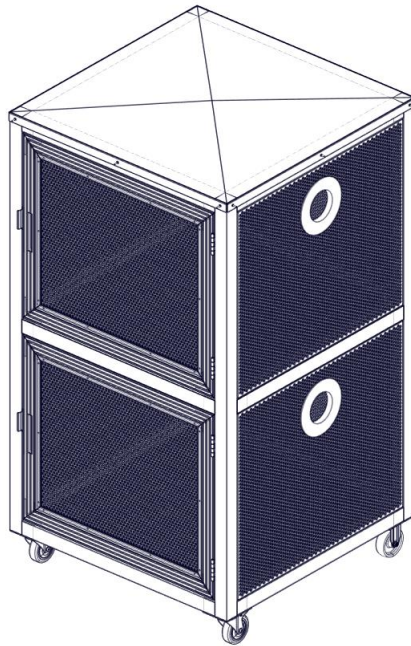
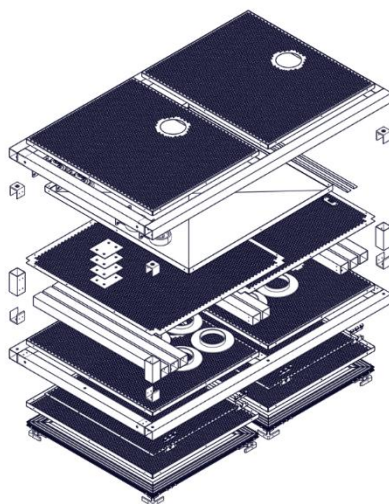
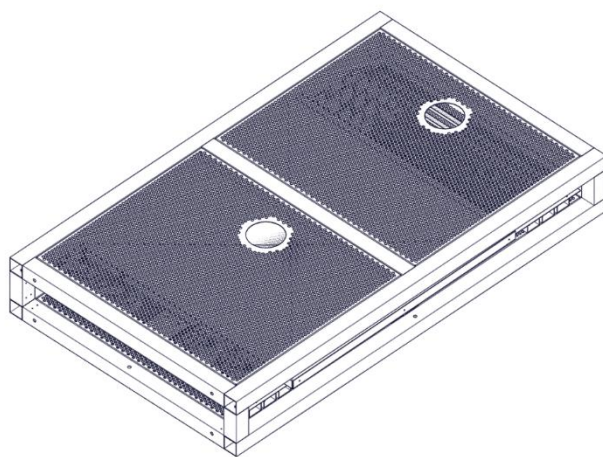

Introduction:

This instruction manual provides a step-by-step guide for assembling the door assembly and the flat pack of recycle bin. The product is designed for easy assembly using a modular extrusion system connected by spigots. All components are referenced using the naming convention and BOM IDs provided in the drawing.

RECYCLE BIN ASSMEBLY INSTRUCTIONS MANUAL

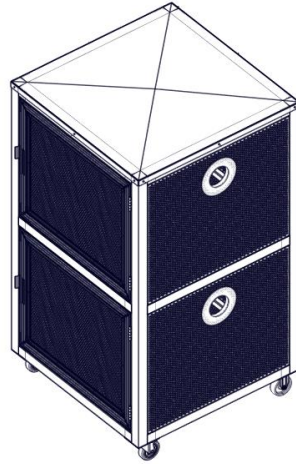

BOM ID	Description	Qty
1	12-14 X 20, SELF DRILLING SCREWS	146
2	CASTOR WHEEL MOUNT PLATE	4
3	DOOR STOPPER	2
4	EXTRUSION, HORIZONTAL, BACK, TOP	1
5	EXTRUSION, HORIZONTAL, BACK, BOTTOM	1
6	EXTRUSION, HORIZONTAL, BACK, MIDDLE	1
7	EXTRUSION, HORIZONTAL, BOTTOM, LEFT	1
8	EXTRUSION, HORIZONTAL, BOTTOM, RIGHT	1
9	EXTRUSION, HORIZONTAL, CENTER, BOTTOM	1
10	EXTRUSION, HORIZONTAL, CENTER, MIDDLE	1
11	EXTRUSION, HORIZONTAL, FRONT, TOP	1
12	EXTRUSION, HORIZONTAL, FRONT, BOTTOM	1
13	EXTRUSION, HORIZONTAL, FRONT, MIDDLE	1

BOM ID	Description	Qty
14	EXTRUSION, HORIZONTAL, MIDDLE, LEFT	1
15	EXTRUSION, HORIZONTAL, MIDDLE, RIGHT	1
16	EXTRUSION, HORIZONTAL, TOP, LEFT	1
17	EXTRUSION, HORIZONTAL, TOP, RIGHT	1
18	EXTRUSION, VERTICAL, BACK	2
19	EXTRUSION, VERTICAL, LEFT	1
20	EXTRUSION, VERTICAL, RIGHT	1
21	FIXED CASTOR WHEEL	2
22	M4 X 10.5, RIVETS	38
23	M8 X 20, FLAT HEAD SCREW	42
24	M8, RIVET NUTS	46
25	PANEL, BACK	2
26	PANEL, ROOF	1

BOM ID	Description	Qty
27	PANEL, SIDE	4
28	SHELVES	2
29	SIGNAGE	8
30	SIGNAGE STRIP	4
31	SPIGOT	28
32	STRIKE	2
33	SWIVEL CASTOR WHEEL	2
34	DOOR ASSEMBLY	2
35	FRONT LEFT, BACK RIGHT PLATE	2
36	FRONT RIGHT, BACK LEFT PLATE	2

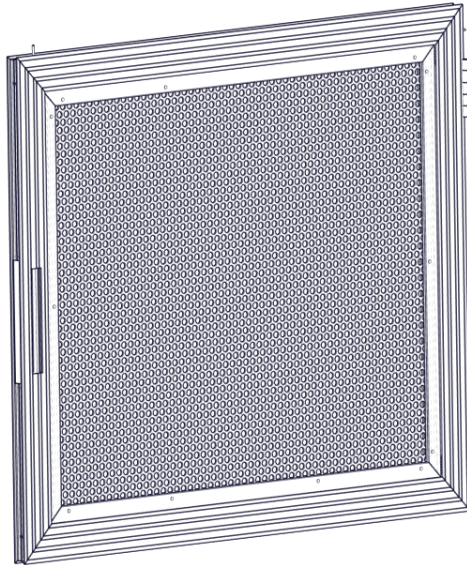

BOM ID	Description	Qty
34-1	BRACKET, DOOR, CORNER STAKE	4
34-2	EXTRUSION, DOOR, HINGE SIDE	1
34-3	EXTRUSION, DOOR, LOCK CUTOUT SIDE	1
34-4	EXTRUSION, DOOR, TOP, BOTTOM	2

BOM ID	Description	Qty
34-5	FILLER, DOOR, SIDE	2
34-6	FILLER, DOOR, TOP, BOTTOM	2
34-7	M4 X 10.5, RIVETS	28
34-8	PANEL, DOOR SHEET	1

BOM ID	Description	Qty
34-9	HINGE ASSEMBLY	2

Tools and Fasteners

The following tools are required for assembly:

- A drill or driver,
- A rivet gun, and
- An appropriate screwdriver or Allen key depending on the fasteners used.

The following fasteners are used throughout the assembly:

- **12-14 X 20, SELF DRILLING SCREWS (Item 1)** are used to secure extrusion connections and panels.
- **M4 X 10.5, RIVETS (Item 22)** and **M4 X 10.5, RIVETS (Item 34-7)** are used for fixing panels, shelves, door extrusions, hinges and the roof.
- **M8 X 20, CSK FLAT HEAD SCREW (Item 23)** and **M8, RIVET NUTS (Item 24)** are used to secure **SPIGOT (Item 31)** to extrusions.
- **A Thread Lock Liquid** on all **M8 X 20, CSK FLAT HEAD SCREW (Item 23)**, to prevent the loosening or disassembly.

Preparation

- Place the flat pack on a clean and level surface.
- Carefully remove the packaging and take out all components placed inside the flat pack.
- Identify and separate all parts including **EXTRUSIONS**, **SPIGOT (Item 31)**, **PANEL, BACK (Item 25)**, **SHELVES (Item 28)**, **DOOR ASSEMBLY (Item 34)**, **CASTOR WHEEL MOUNT PLATE (Item 2)**, **FIXED CASTOR WHEEL (Item 21)**, **SWIVEL CASTOR WHEEL (Item 33)**, and all hardware.
- Keep all fasteners such as **12-14 X 20, SELF DRILLING SCREWS (Item 1)**, **M4 X 10.5, RIVETS (Item 22)**, **M8, RIVET NUTS (Item 24)**, and **M8 X 20, CSK FLAT HEAD SCREW (Item 23)** easily accessible.

Opening the Flat Pack Structure

- Place the flat pack assembly such that the two frames can be separated.
- Remove the **12-14 X 20, SELF DRILLING SCREWS (Item 1)** securing the right frame to the temporary pillars.
- Carefully separate the right frame from the left frame and remove the temporary pillars.

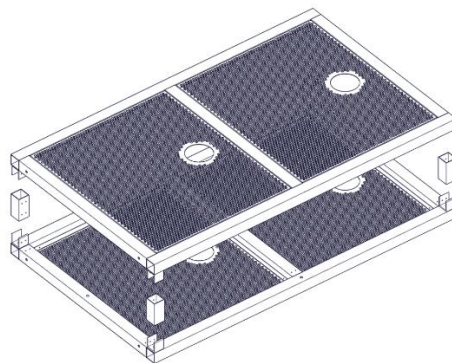

- Retain the left and right frames in an upright position for further assembly.

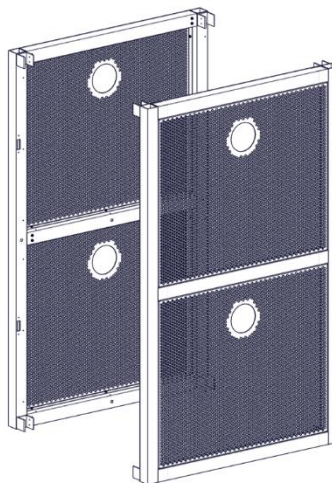

Assembly of Main Frame

- Position the left frame upright and keep the right frame aside for later installation.
- Ensure all required **SPIGOT (Item 31)** are installed on the left frame vertical extrusions at the top, middle, and bottom positions, including locations required for centre supports, using **M8, RIVET NUTS (Item 24)** and **M8 X 20, CSK FLAT HEAD SCREW (Item 23)**.

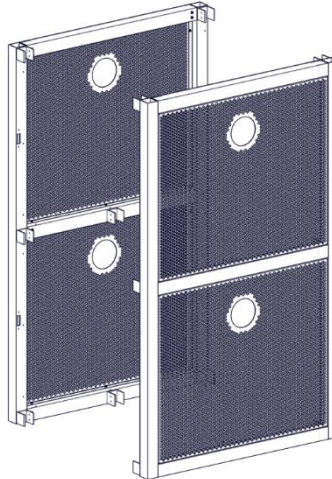

- Take **EXTRUSION, HORIZONTAL, BACK, TOP (Item 4)**, **EXTRUSION, HORIZONTAL, BACK, MIDDLE (Item 6)**, and **EXTRUSION, HORIZONTAL, BACK, BOTTOM (Item 5)** and insert them onto the corresponding spigots on the left frame. Ensure each extrusion is fully seated and properly aligned.

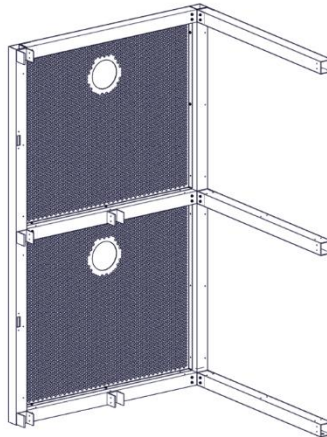

- Now take **EXTRUSION, HORIZONTAL, CENTER, MIDDLE (Item 10)** and **EXTRUSION, HORIZONTAL, CENTER, BOTTOM (Item 9)** and insert them onto the corresponding spigots on the left frame. These extrusions will support the shelves and must be installed at this stage.

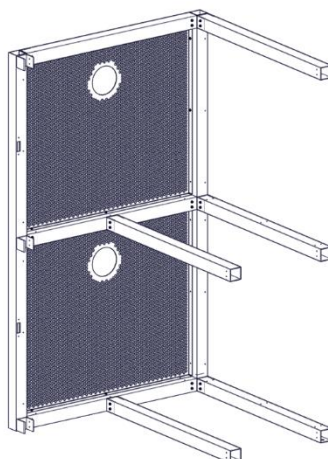

- Repeat the same process on the front side using **EXTRUSION, HORIZONTAL, FRONT, TOP (Item 11)**, **EXTRUSION, HORIZONTAL, FRONT, MIDDLE (Item 13)**, and **EXTRUSION, HORIZONTAL, FRONT, BOTTOM (Item 12)**, mounting all extrusions onto the left frame first.

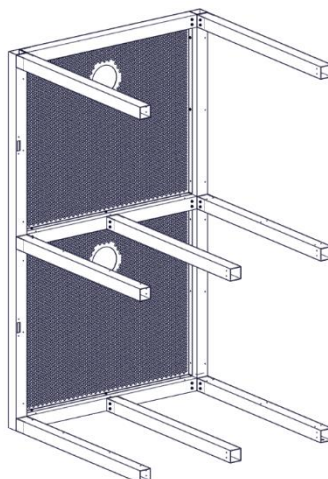

- Once all horizontal extrusions, including front, back, and centre members, are mounted onto the left frame, bring the right frame into position.
- Carefully align the right frame with the free ends of all horizontal extrusions and insert the extrusions into their corresponding locations on the right frame. Ensure all members are properly aligned before fastening.

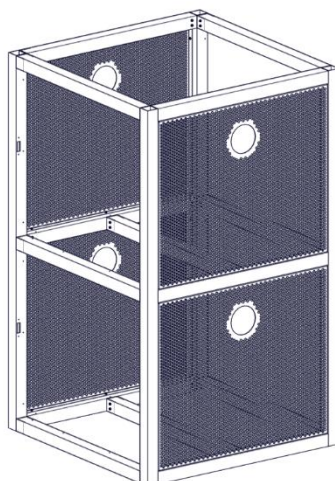

- After full alignment, secure all connections using **12-14 X 20, SELF DRILLING SCREWS (Item 1)** by driving screws through the horizontal extrusions into the spigots.
- Check that all extrusions are fully seated, the frame is square, and all connections are tightened to form a rigid and stable structure.

Installation of Back Panels

- Once the extrusions are properly mounted, take the **PANEL, BACK (Item 25)**.
- Position the **PANEL, BACK (Item 25)** onto the rear side of the frame.
- Align the panel with the outer edges of the frame.
- Secure the **PANEL, BACK (Item 25)** to the frame using **12-14 X 20, SELF DRILLING SCREWS (Item 1)**, ensuring it is firmly fixed and flush with the frame.

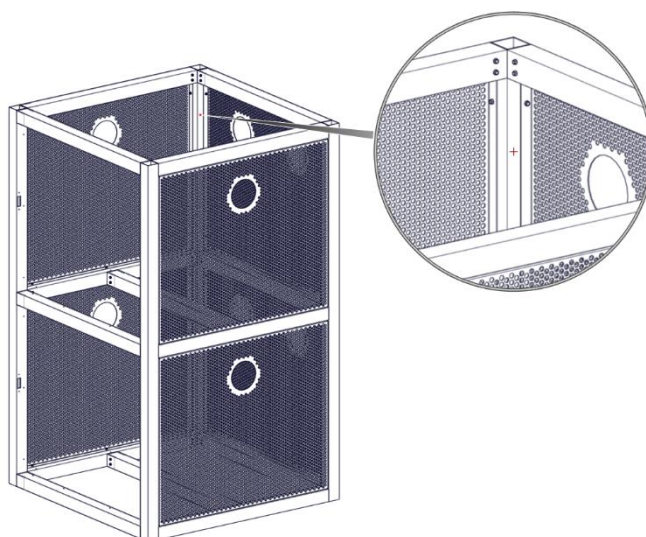

Installation of Shelves

- Take the **SHELVES (Item 28)** and place them at the middle and bottom levels inside the frame.

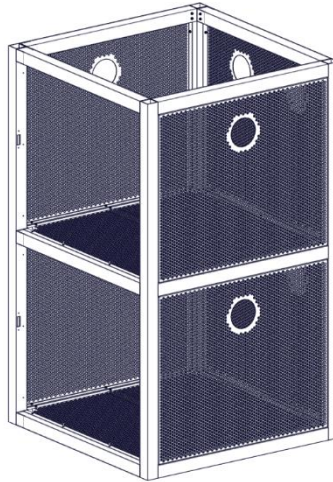

- Ensure the shelves rest on the side horizontal extrusions and the center support extrusions.
- Secure the shelves using **M4 X 10.5, RIVETS (Item 22)** at the front and **12-14 X 20, SELF DRILLING SCREWS (Item 1)** along the sides and back.

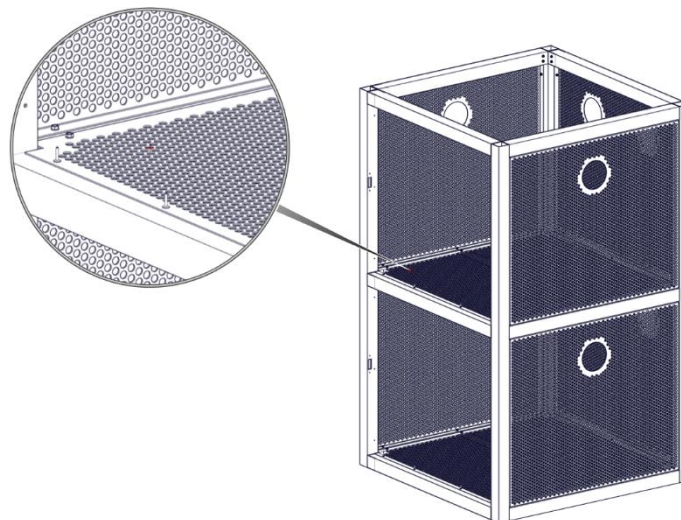

- Ensure the shelves are level and firmly secured.

Installation of Doors

- Take the **DOOR ASSEMBLY (Item 34)** and position it at the front of the frame.
- Install the **DOOR STOPPER (Item 3)** and **STRIKE (Item 32)** onto the corresponding vertical extrusion.

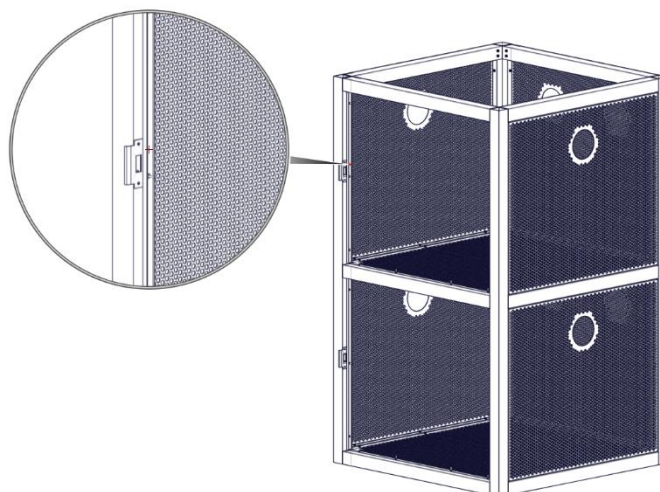

- Align the hinges with the mounting points on the vertical extrusion.
- Secure the hinges using **M4 X 10.5, RIVETS (Item 22)**.

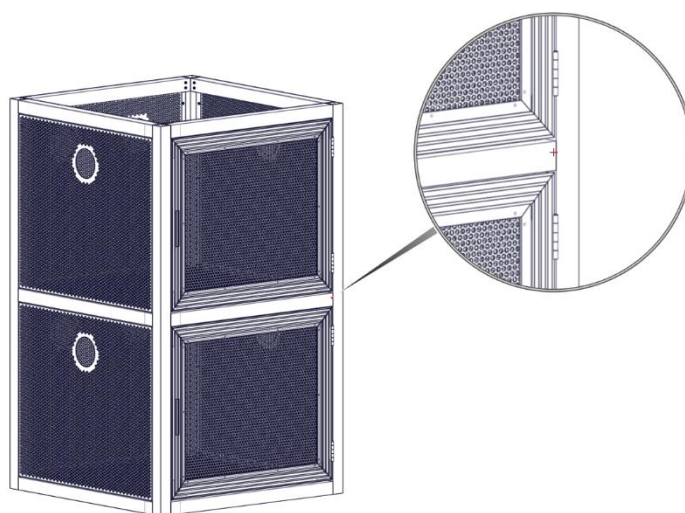

- Check that the door opens and closes smoothly and aligns correctly.

Installation of Castor Wheels

- Place the partially assembled frame on its side to allow access to the bottom horizontal extrusions.
- Prepare two types of mounting plate sub-assemblies using:
 - **FRONT RIGHT, BACK LEFT PLATE (Item 35)**
 - **FRONT LEFT, BACK RIGHT PLATE (Item 36)**
- Create two sub-assemblies of each type:
 - The **FRONT RIGHT, BACK LEFT PLATE (Item 35)** will be used at the front right and back left positions

- The **FRONT LEFT, BACK RIGHT PLATE (Item 36)** will be used at the front left and back right positions
- For the **FRONT RIGHT, BACK LEFT PLATE (Item 35)**:
 - Install **M8, RIVET NUTS (Item 24)** into the diagonal holes that does not align with the mounting holes on the horizontal extrusions
 - Ensure rivet nuts are placed on the correct diagonal so that the plate matches both front right and back left orientations

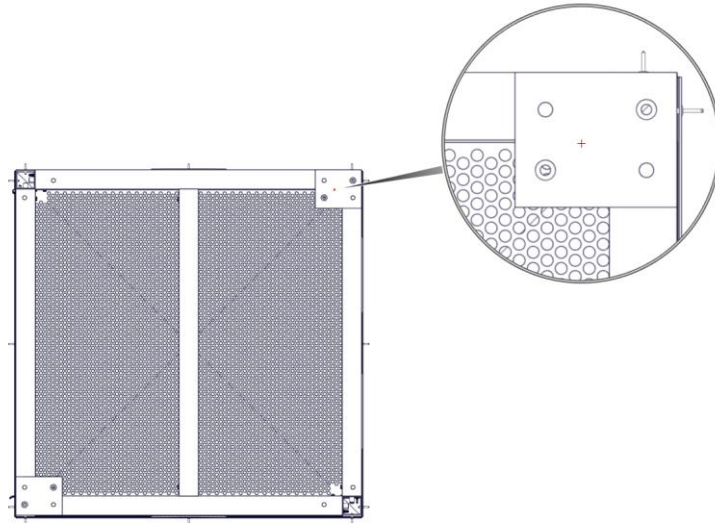

- For the **FRONT LEFT, BACK RIGHT PLATE (Item 36)**:
 - Install **M8, RIVET NUTS (Item 24)** in the opposite diagonal configuration compared to Item 35
 - This ensures correct alignment with extrusion mounting holes for front left and back right positions

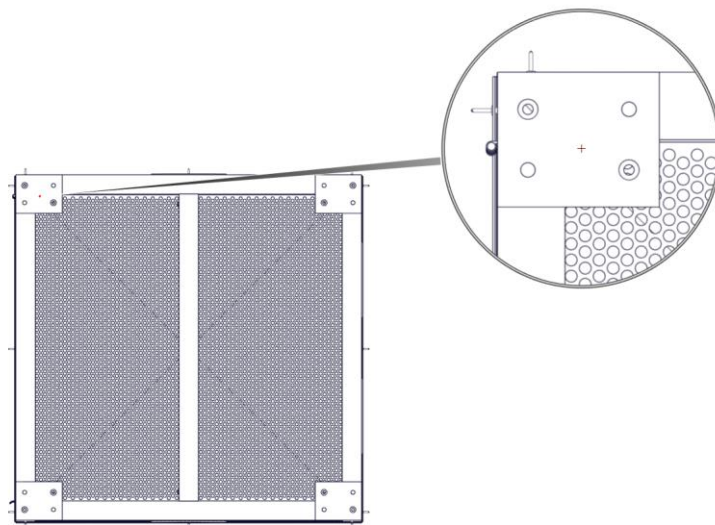

- Identify the mounting locations on the frame:

- Mounting holes are pre-provided on
 - **EXTRUSION, HORIZONTAL, FRONT, BOTTOM (Item 12)**
 - **EXTRUSION, HORIZONTAL, BACK, BOTTOM (Item 5)**
 - **EXTRUSION, HORIZONTAL, BOTTOM, LEFT (Item 7)**
 - **EXTRUSION, HORIZONTAL, BOTTOM, RIGHT (Item 8)**

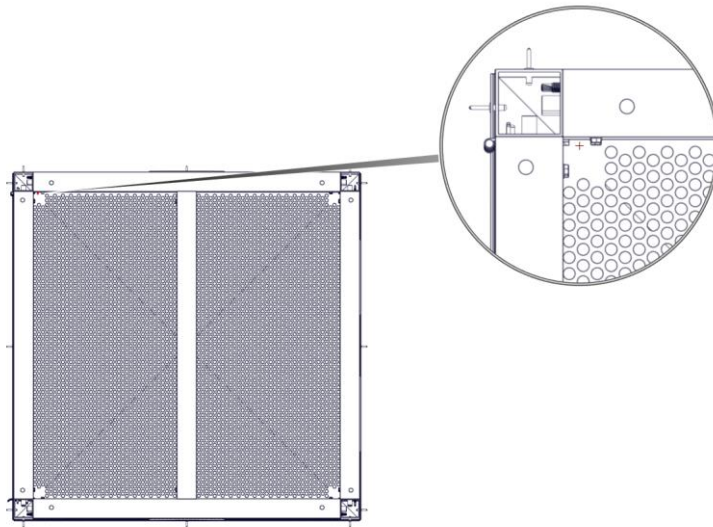

- Position each plate onto the corresponding corner of the frame and align with the extrusion holes.
- Secure all plates using:
 - **M8 X 20, FLAT HEAD SCREW (Item 23)** into the installed **M8, RIVET NUTS (Item 24)**

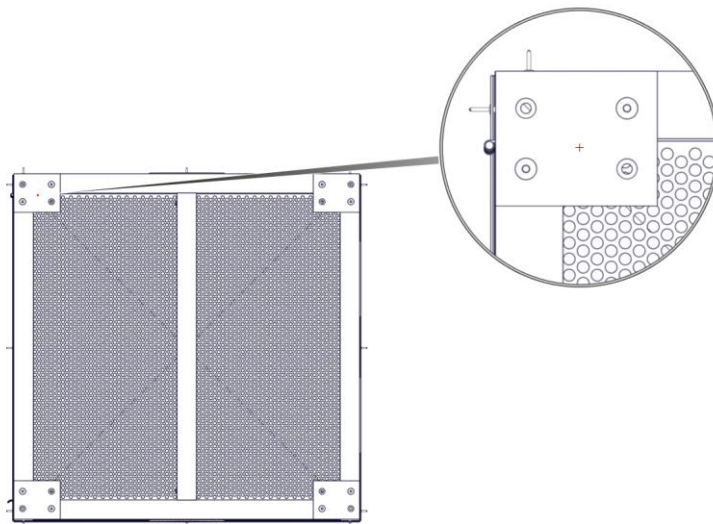

- After all plates are mounted, install the wheels:
 - Attach **SWIVEL CASTOR WHEEL (Item 33)** on the front side (door side)
 - Attach **FIXED CASTOR WHEEL (Item 21)** on the back side

- Secure all wheels to the mounting plates using the appropriate fasteners provided with the wheels.

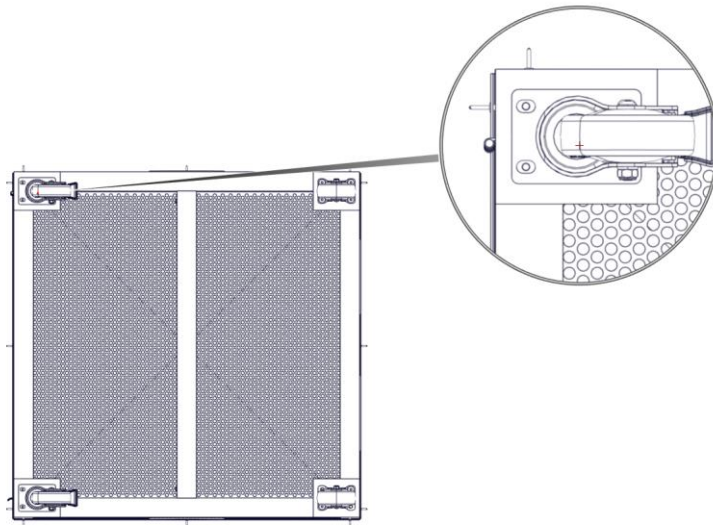

- Return the assembly to its upright position and ensure all wheels are properly aligned and securely fixed

Installation of Roof

- Place the **PANEL, ROOF (Item 23)** on top of the frame.
- Align the roof with the top horizontal extrusions.
- Secure the roof using **M4 X 10.5, RIVETS (Item 22)** along all edges.

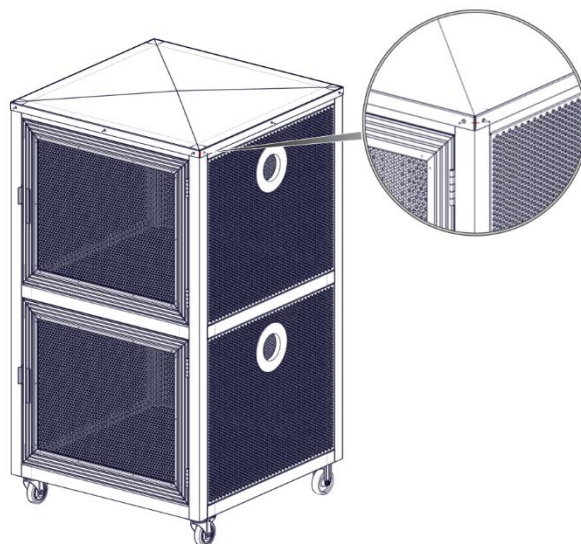

Installation of Signage

- Take the **SIGNAGE (Item 29)** and apply double-sided tape on the back side.
- Align the signage with the pre-cut circular openings in the panels.

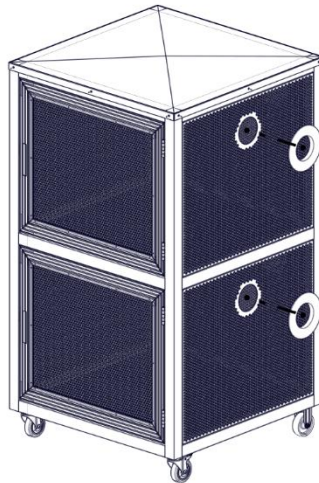

- Take the **SIGNAGE STRIP (Item 34)** and install it on all four **EXTRUSION, HORIZONTAL, MIDDLE** extrusions.
- Start by placing the **SIGNAGE STRIP (Item 34)** on the **EXTRUSION, HORIZONTAL, FRONT, MIDDLE (Item 12)**, ensuring it is aligned correctly.

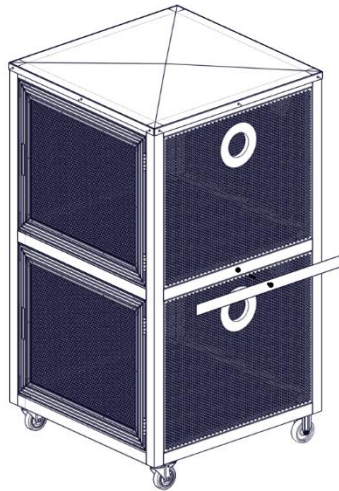

- Repeat this on the **EXTRUSION, HORIZONTAL, BACK, MIDDLE (Item 6)**, **EXTRUSION, HORIZONTAL, LEFT, MIDDLE (Item 13)**, and **EXTRUSION, HORIZONTAL, RIGHT, MIDDLE (Item 14)** extrusions.
- Secure the **SIGNAGE STRIP (Item 34)** in place by pressing it firmly onto the pre-marked locations on all four middle horizontal extrusions of the frame. The double-sided tape will hold the strip in place securely.

Final Inspection

- Check that all **12-14 X 20, SELF DRILLING SCREWS (Item 1)**, **M4 X 10.5, RIVETS (Item 22)**, and all fasteners are properly secured.

- Ensure the structure is stable and square.
 - Verify that the shelves are properly seated and secured.
 - Check that the doors open and close smoothly without interference.
 - Confirm that the wheels rotate freely and the unit moves easily.
- The recycle bin is now fully assembled from the flat pack and ready for use.

